

VIELSEITIGE AUFBAUSYSTEME DES SYSTÈMES DE CONSTRUCTION VARIÉS

Aluminium Rungen
CS MAX, CS MIDI, CS MINI, KIMAX

Montants en aluminium
CS MAX, CS MIDI, CS MINI, KIMAX

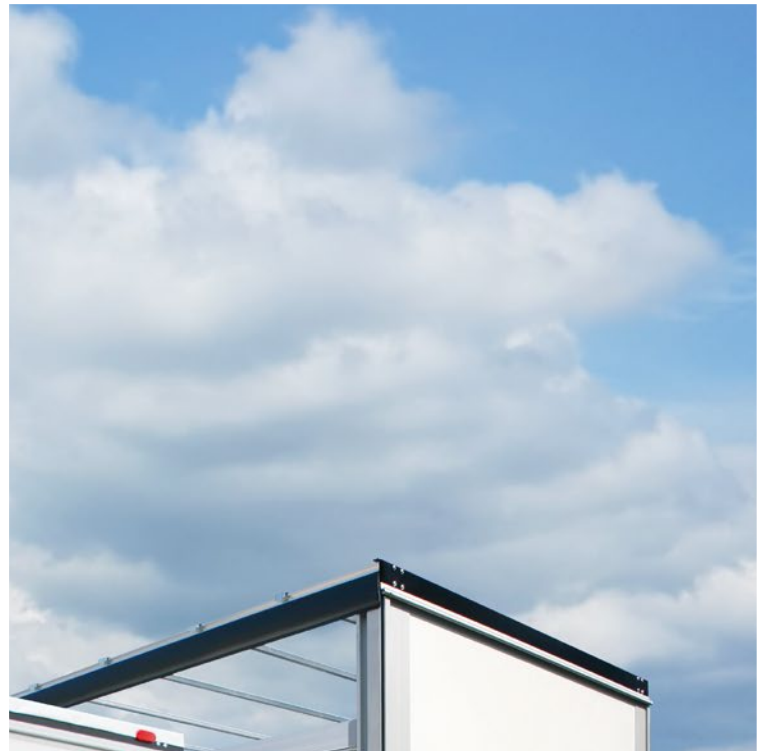

CS MAX EN 12642-XL

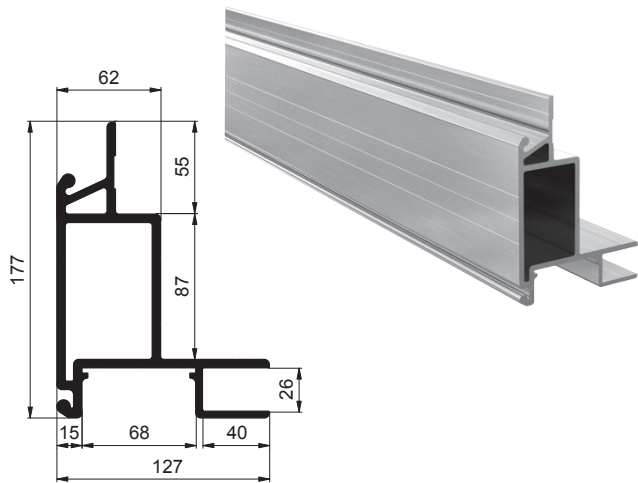

Vorderrunge
Montant avant

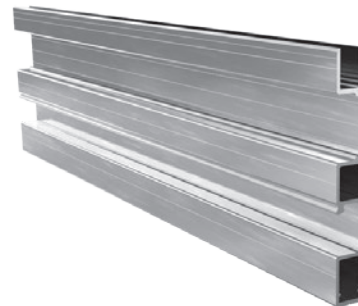

Hinterrunge
Montant arrière

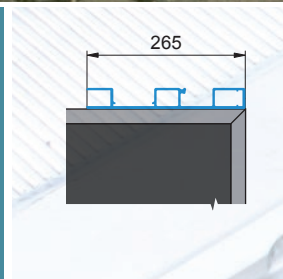
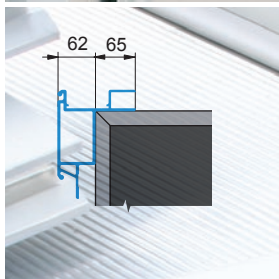
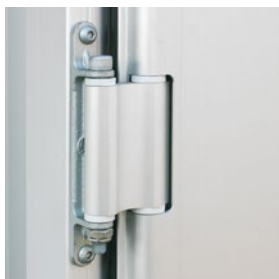

CS MIDI

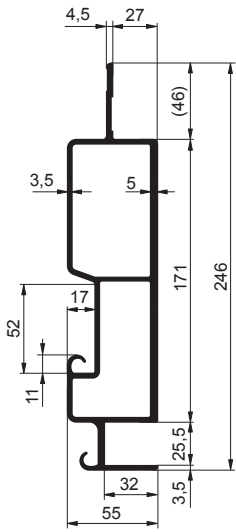

Vorderrunge flach
Montant avant plat

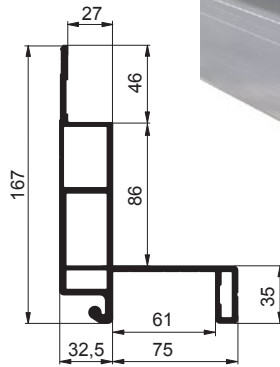

Vorderrunge
Montant avant

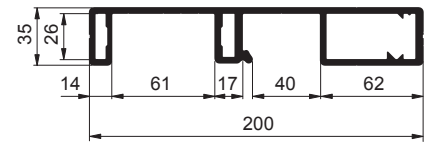

Hinterrunge
Montant arrière

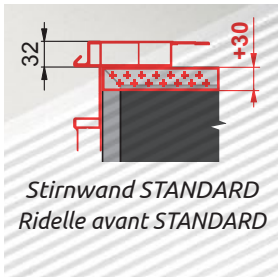
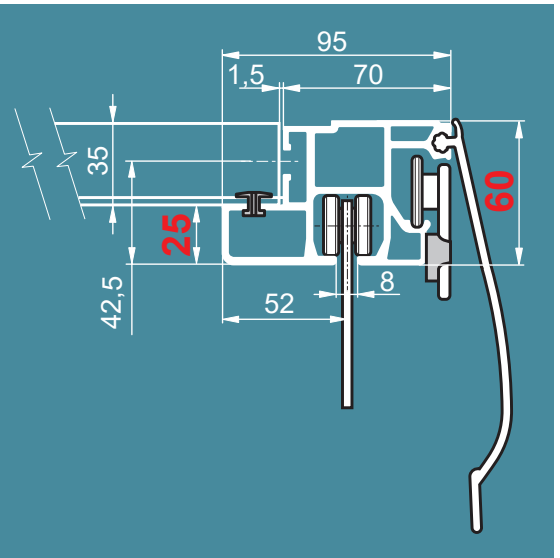

Stirnwand STANDARD
Ridelle avant STANDARD

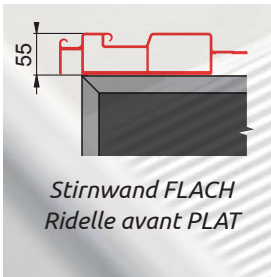

Stirnwand FLACH
Ridelle avant PLAT

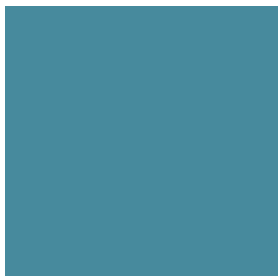

CS MINI

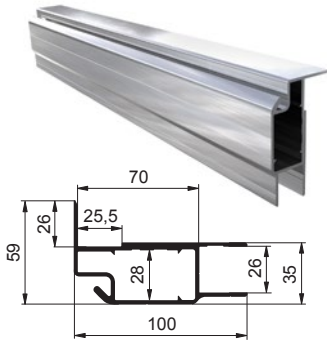

*Vorderrunge mit Einfass
Montant avant avec bordure*

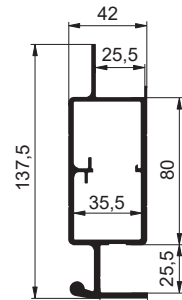

*Vorderrunge flach
Montant avant plat*

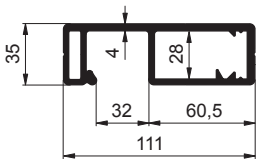
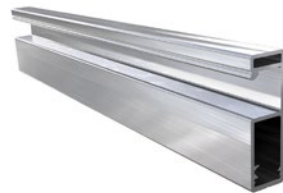

*Hinterrunge uni
Montant arrière uni*

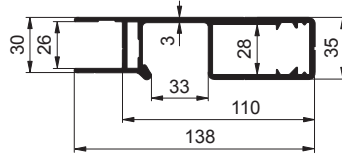
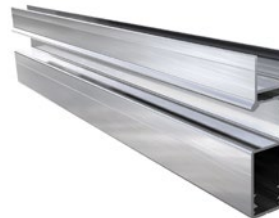

*Hinterrunge für Türen
Montant arrière pour les portes*

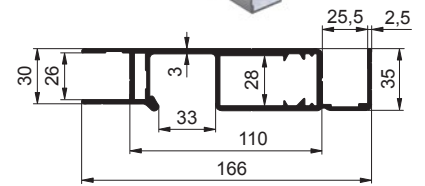

*Hinterrunge mit Einfass
Montant arrière avec bordure*

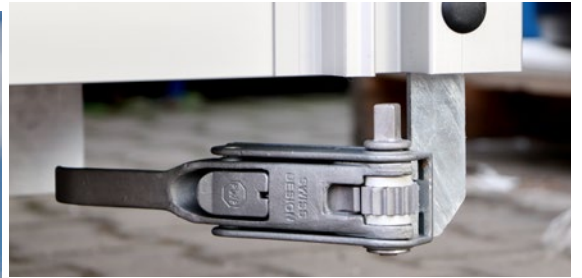

HUBDACHSYSTEM für CS MINI Aufbau mit Höhenabsenkung von 300 mm
SYSTÈME DE TOIT RELEVABLE pour structure CS MINI avec réduction de la hauteur de 300 mm



KIMAX

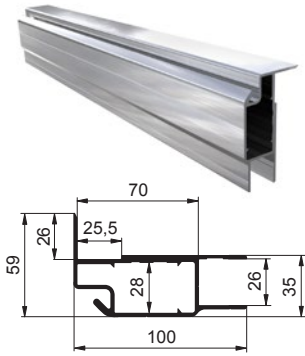

Vorderrunge mit Einfass
Montant avant avec bordure

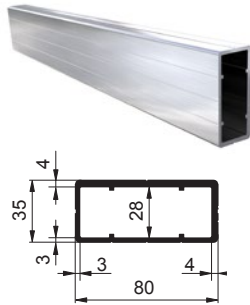

Runge 80 mm
Montant 80 mm

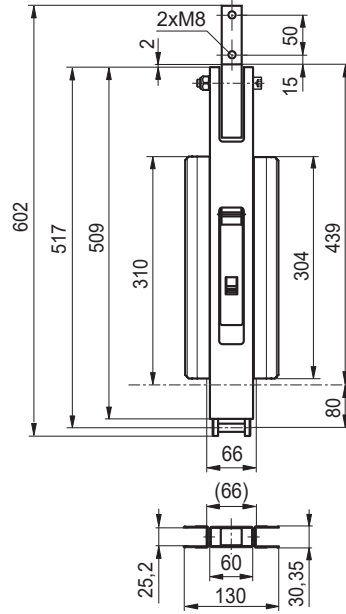

HUBDACHSYSTEM für KIMAX Aufbau mit Höhenabsenkung von 300mm

SYSTÈME DE TOIT RELEVABLE pour structure KIMAX avec réduction de la hauteur de 300 mm



DIESE TABELLE GIBT AN, WELCHE RUNGEN UND DACHGURTPROFILE LAUT FAHRZEUGGESAMTGEWICHT EINSETZBAR SIND.

RUNGEN / AUFBAUTYP	MAX. AUSSENMASSE VOM AUFBAU [m] LÄNGE X HÖHE [MAX. BREITE 2,55m]	GESAMTGEWICHT					
		3,5 t	5t	7,5t	12t	18t	26t
CS MAX (Dach S)	bis 8,5 × 3,15				•	•	
CS MAX laut Zert. EN 12642 XL	bis 9,6 × 3,1						•
CS MAX mit LBW hinten	bis 7,4 × 2,8				•	•	
CS MIDI (Dach S)	bis 8,5 × 3,00		•	•	•		
CS MIDI (Dach M)	bis 9,5 × 3,00			•	•		
CS MIDI (Dach L)	bis 9,5 × 3,00			•	•		
CS MIDI mit LBW hinten	bis 6,0 × 2,5		•	•			
CS MINI (Dach S)	bis 6,0 × 2,6	•	•	•			
CS MINI mit Hecktür	bis 4,0 × 2,2	•	•				
CS MINI mit LBW hinten	bis 4,0 × 2,2	•					
CS MINI mit zwei Fahrpositionen**	bis 5,0 × 2,6*	•	•				
KIMAX mit zwei Fahrpositionen***	bis 5,0 × 2,7*	•	•				

Technische Information:

Die o.a. Tabelle betrifft Standardaufbauten. In Sonderfällen empfehlen wir den Rungentyp mit unserem Vertrieb zu besprechen.

* Höhe angegeben in zweiter Fahrposition

** Nur mit Dachgurtprofil Small möglich, nicht mit Hecktür oder LBW hinten kombinierbar

*** nicht mit Hecktür oder LBW hinten kombinierbar

CE TABLEAU INDIQUE QUELS MONTANTS ET QUELS PROFILÉS SUPÉRIEURS DE TOIT PEUVENT ÊTRE UTILISÉS EN FONCTION DU POIDS TOTAL DU VÉHICULE

MONTANTS / TYPE DE STRUCTURE	DIMENSIONS EXTÉRIEURES MAX. DE LA STRUCTURE [m] LONGUEUR X HAUTEUR [LARGEUR MAX. 2,55 m]	POIDS TOTAL					
		3,5 t	5t	7,5t	12t	18t	26t
CS MAX (toit S)	jusqu'à 8,5 × 3,15				•	•	
CS MAX selon cert. EN 12642 XL	jusqu'à 9,6 × 3,1						•
CS MAX avec hayon arrière de chargement	jusqu'à 7,4 × 2,8				•	•	
CS MIDI (toit S)	jusqu'à 8,5 × 3,00		•	•	•		
CS MIDI (toit M)	jusqu'à 9,5 × 3,00			•	•		
CS MIDI (toit L)	jusqu'à 9,5 × 3,00			•	•		
CS MIDI avec hayon arrière de chargement	jusqu'à 6,0 × 2,5		•	•			
CS MINI (toit S)	jusqu'à 6,0 × 2,6	•	•	•			
CS MINI avec hayon arrière	jusqu'à 4,0 × 2,2	•	•				
CS MINI avec hayon arrière de chargement	jusqu'à 4,0 × 2,2	•					
CS MINI à deux directions**	jusqu'à 5,0 × 2,6*	•	•				
KIMAX à deux directions ***	jusqu'à 5,0 × 2,7*	•	•				

Informations techniques:

Le tableau ci-dessus concerne les structures standard. Dans des cas particuliers, nous recommandons de consulter notre service commercial afin de déterminer le type de montant adapté.

* hauteur indiquée dans la deuxième position directionnelle

** uniquement possible avec le profilé supérieur de toit Small, ne peut être combiné avec le hayon arrière ou le hayon arrière de chargement

*** ne peut pas être combiné avec le hayon arrière ou le hayon arrière de chargement

